

NTC Thermistors, Accuracy Line

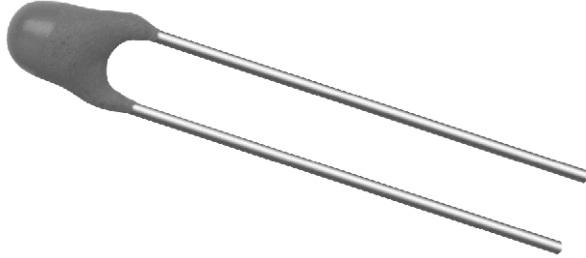

FEATURES

- Accuracy over a wide temperature range
- High stability over a long life
- Excellent price/performance ratio
- Old part number was 2322 640 3/4/6....
- Component in accordance to RoHS 2002/95/EC and WEEE 2002/96/EC

APPLICATIONS

- Temperature sensing and control

These thermistors have a negative temperature coefficient. The device consists of a chip with two tinned solid copper-plated leads. It is grey lacquered and colour coded, but not insulated.

PACKAGING

The thermistors are packed in bulk or tape on reel; see code numbers and relevant packaging quantities.

MARKING

The thermistors are marked with coloured bands; see dimensions drawing and "Electrical data and ordering information".

MOUNTING

By soldering in any position.

QUICK REFERENCE DATA	
PARAMETER	VALUE
Resistance value at 25 °C	3.3 Ω to 470 kΩ
Tolerance on R ₂₅ - value	± 2 %; ± 3 %; ± 5 %; ± 10 %
Tolerance on B _{25/85} - value	± 0.5 % to ± 3 %
Maximum dissipation	500 mW
Dissipation factor δ (for information only)	7 mW/K 8.5 mW/K (for 640..338 to 689)
Response time	1.2 s
Thermal time constant τ (for information only)	15 s
Operating temperature range: at zero dissipation; continuously	- 40 to + 125 °C
at zero dissipation; for short periods	≤ 150 °C
at maximum dissipation (500 mW)	0 to 55 °C
Climatic category	40/125/56
Mass	≈ 0.3 g

ELECTRICAL DATA AND ORDERING INFORMATION								
R ₂₅ (Ω)	B _{25/85} - VALUE		UL APPROVED (Y/N)	12NC ORDERING CODE 2381 640 6.... ¹⁾	SAP MATERIAL NO. NTCLE100E3..... ²⁾	COLOR CODE ³⁾		
	(K)	(± %)				I	II	III
3.3	2880	3	N	*338	338*B0	orange	orange	gold
4.7	2880	3	N	*478	478*B0	yellow	violet	gold
6.8	2880	3	N	*688	688*B0	blue	grey	gold
10	2990	3	N	*109	109*B0	brown	black	black
15	3041	3	N	*159	159*B0	brown	green	black
22	3136	3	N	*229	229*B0	red	red	black
33	3390	3	Y	*339	339*B0	orange	orange	black
47	3390	3	Y	*479	479*B0	yellow	violet	black
68	3390	3	Y	*689	689*B0	blue	grey	black
100	3560	0.75	N	*101	101*B0	brown	black	brown
150	3560	0.75	N	*151	151*B0	brown	green	brown
220	3560	0.75	N	*221	221*B0	red	red	brown
330	3560	0.75	N	*331	331*B0	orange	orange	brown
470	3560	0.75	N	*471	471*B0	yellow	violet	brown
680	3560	0.75	N	*681	681*B0	blue	grey	brown
1000	3528	0.5	N	*102	102*B0	brown	black	red
1500	3528	0.5	N	*152	152*B0	brown	green	red

ELECTRICAL DATA AND ORDERING INFORMATION								
R ₂₅ (Ω)	B _{25/85} - VALUE (K)		UL APPROVED (Y/N)	12NC ORDERING CODE 2381 640 6.... ¹⁾	SAP MATERIAL NO. NTCLE100E3..... ²⁾	COLOR CODE ³⁾		
	(± %)					I	II	III
2000	3528	0.5	N	*202	202*B0	red	black	red
2200	3977	0.75	Y	*222	222*B0	red	red	red
2700	3977	0.75	Y	*272	272*B0	red	violet	red
3300	3977	0.75	Y	*332	332*B0	orange	orange	red
4700	3977	0.75	Y	*472	472*B0	yellow	violet	red
5000	3977	0.75	Y	*502	502*B0	green	black	red
6800	3977	0.75	Y	*682	682*B0	blue	grey	red
10 000	3977	0.75	Y	*103	103*B0	brown	black	orange
12 000	3740	2	Y	*123	123*B0	brown	red	orange
15 000	3740	2	Y	*153	153*B0	brown	green	orange
22 000	3740	2	Y	*223	223*B0	red	red	orange
33 000	4090	1.5	N	*333	333*B0	orange	orange	orange
47 000	4090	1.5	N	*473	473*B0	yellow	violet	orange
50 000	4190	1.5	N	*503	503*B0	green	black	orange
68 000	4190	1.5	N	*683	683*B0	blue	grey	orange
100 000	4190	1.5	N	*104	104*B0	brown	black	yellow
150 000	4370	2.5	Y	*154	154*B0	brown	green	yellow
220 000	4370	2.5	Y	*224	224*B0	red	red	yellow
330 000	4570	1.5	N	*334	334*B0	orange	orange	yellow
470 000	4570	1.5	N	*474	474*B0	yellow	violet	yellow

Notes

1. Replace * in 12NC by 2 for 10 %, 3 for 5 %, 6 for 3 %, 4 for 2 %
2. Replace * in SAP by K for 10 %, J for 5 %, H for 3 %, G for 2 %
3. For R₂₅ ± 2 % band IV is red, ± 3 % band IV is orange, ± 5 % band IV is gold and ± 10 % band IV is silver

DIMENSIONS in millimeters

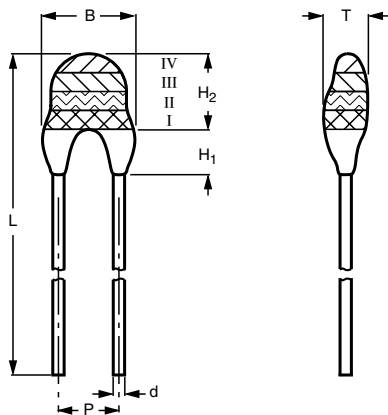

2381 640 6.338 to 6.474

DERATING AND TEMPERATURE TOLERANCES

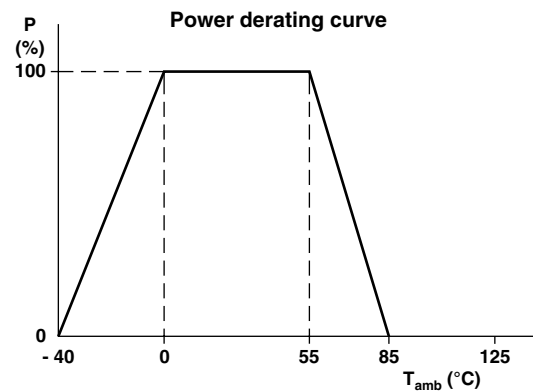

PHYSICAL DIMENSIONS FOR RELEVANT TYPE								
CODE NUMBER 2381 640	Bmax	d	H ₁		H ₂ MAX	L	P	Tmax
			MIN.	MAX.				
6.338 to 6.221	5.0	0.6 ± 0.06	1.0	4.0	6.0	24 ± 1.5	2.54	4.0
6.331 to 6.474	3.3 ± 0.5	0.6 ± 0.06	-	2.0 ± 1.0	6.0	24 ± 1.5	2.54	3.0



TEMPERATURE DEVIATION AS A FUNCTION OF THE AMBIENT TEMPERATURE

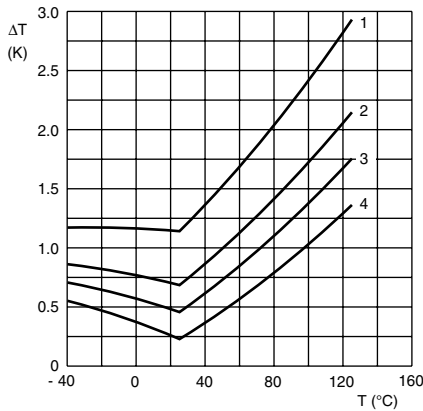

Curves valid for 2.2 to 10 kΩ
Curve 1: ΔR25/R25 = 5 %
Curve 2: ΔR25/R25 = 3 %
Curve 3: ΔR25/R25 = 2 %
Curve 4: ΔR25/R25 = 1 %
(for 2381 640 5.... series only)

TEMPERATURE DEVIATION AS A FUNCTION OF THE AMBIENT TEMPERATURE

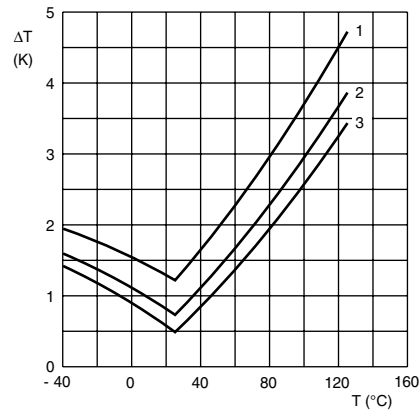

Curves valid for 12 to 22 kΩ
Curve 1: ΔR25/R25 = 5 %
Curve 2: ΔR25/R25 = 3 %
Curve 3: ΔR25/R25 = 2 %

TEMPERATURE DEVIATION AS A FUNCTION OF THE AMBIENT TEMPERATURE

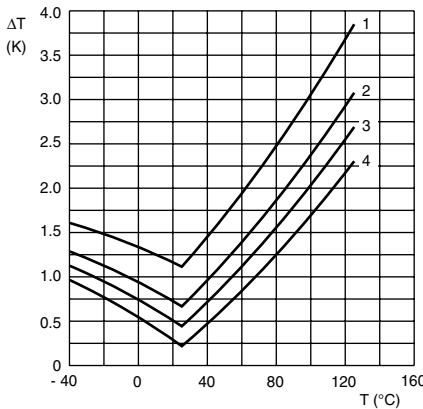

Curves valid for 33 to 47 kΩ
Curve 1: ΔR25/R25 = 5 %
Curve 2: ΔR25/R25 = 3 %
Curve 3: ΔR25/R25 = 2 %
Curve 4: ΔR25/R25 = 1 %
(for 2381 640 5.... series only)

TEMPERATURE DEVIATION AS A FUNCTION OF THE AMBIENT TEMPERATURE

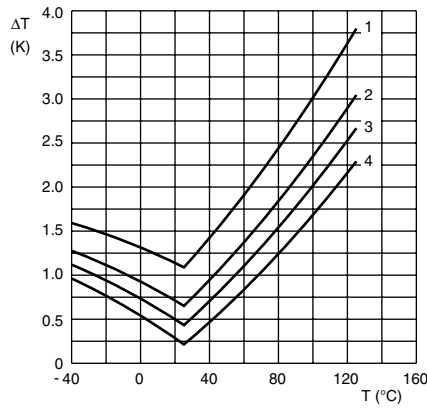

Curves valid for 68 to 100 kΩ
Curve 1: ΔR25/R25 = 5 %
Curve 2: ΔR25/R25 = 3 %
Curve 3: ΔR25/R25 = 2 %
Curve 4: ΔR25/R25 = 1 %
(for 2381 640 5.... series only)

TEMPERATURE DEVIATION AS A FUNCTION OF THE AMBIENT TEMPERATURE

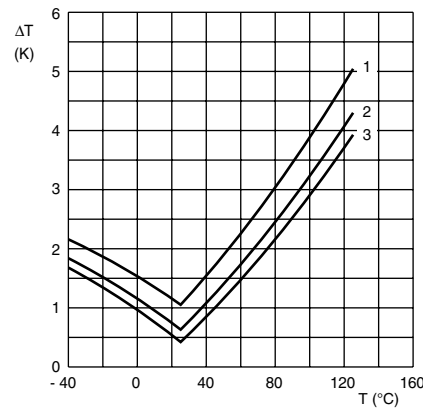

Curves valid for 150 to 220 kΩ
Curve 1: ΔR25/R25 = 5 %
Curve 2: ΔR25/R25 = 3 %
Curve 3: ΔR25/R25 = 2 %

TEMPERATURE DEVIATION AS A FUNCTION OF THE AMBIENT TEMPERATURE

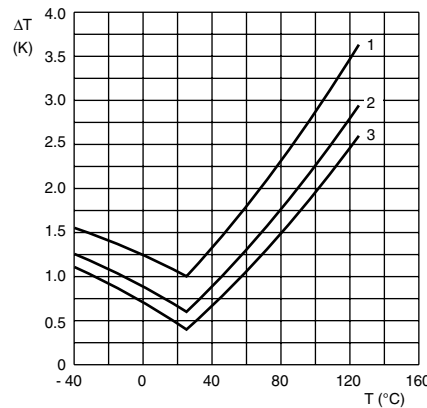

Curves valid for 330 to 470 kΩ
Curve 1: ΔR25/R25 = 5 %
Curve 2: ΔR25/R25 = 3 %
Curve 3: ΔR25/R25 = 2 %



R_T VALUE AND TOLERANCE

These thermistors have a narrow tolerance on the B-value, the result of which provides a very small tolerance on the nominal resistance value over a wide temperature range. For this reason the usual graphs of R = f(T) are replaced by Resistance Values at Intermediate Temperatures Tables, together with a formula to calculate the characteristics with a high precision.

FORMULAE TO DETERMINE NOMINAL RESISTANCE VALUES

The resistance values at intermediate temperatures, or the operating temperature values, can be calculated using the following interpolation laws (extended "Steinhart and Hart"):

$$R(T) - R_{ref} \times e^{(A+B/T+B/T^2+C/T^3)} \quad (1)$$

$$T(R) = \left(A_1 + B_1 \ln \frac{R}{R_{ref}} + C_1 \ln^2 \frac{R}{R_{ref}} + D_1 \ln^3 \frac{R}{R_{ref}} \right)^{-1} \quad (2)$$

where:

A, B, C, D, A₁, B₁, C₁ and D₁ are constant values depending on the material concerned; see table below.

R_{ref} is the resistance value at a reference temperature (in this event 25 °C).

T is the temperature in K.

Formulae numbered 1 and 2 are interchangeable with an error of max. 0.005 °C in the range 25 °C to 125 °C and max. 0.015 °C in the range - 40 °C to + 25 °C.

DETERMINATION OF THE RESISTANCE/TEMPERATURE DEVIATION FROM NOMINAL VALUE

The total resistance deviation is obtained by combining the 'R₂₅-tolerance' and the 'resistance deviation due to B-tolerance'.

When:

- X = R₂₅-tolerance
- Y = resistance deviation due to B-tolerance
- Z = complete resistance deviation,

then: $Z = \left[\left(1 + \frac{X}{100} \right) \times \left(1 + \frac{Y}{100} \right) - 1 \right] \times 100 \%$ or $Z \approx X + Y$

When:

- TCR = temperature coefficient
- ΔT = temperature deviation,

then: $\Delta T = \frac{Z}{TCR}$

The temperature tolerances are plotted in the graphs on the previous page.

Example: at 0 °C, assume X = 5 %, Y = 0.89 % and TCR = 5.08 %/K (see Table), then:

$$Z = \left\{ \left[1 + \frac{5}{100} \right] \times \left[1 + \frac{0.89}{100} \right] - 1 \right\} \times 100 \%$$

$$= \{ 1.05 \times 1.0089 - 1 \} \times 100 \% = 5.9345 \% (\approx 5.93 \%)$$

$$\Delta T = \frac{Z}{TCR} = \frac{5.93}{5.08} = 1.167 \text{ } ^\circ\text{C} (\approx 1.17 \text{ } ^\circ\text{C})$$

A NTC with a R₂₅ - value of 10 kΩ has a value of 32.56 kΩ between - 1.17 and + 1.17 °C.

PARAMETER FOR DETERMINING NOMINAL RESISTANCE VALUES

NUMBER	B _{25/85} (K)	NAME	TOL. B VALUE %	A	B (K)	C (K ²)	D (K ³)	A ₁	B ₁ (K ⁻¹)	C ₁ (K ⁻²)	D ₁ (K ⁻³)
1	2880	mat O. with Bn = 2880K	3	-9.094	2251.74	229098	-2.744820E+07	3.354016E-03	3.495020E-04	2.095959E-06	4.260615E-07
2	2990	mat P. with Bn = 3990K	3	-10.2296	2887.62	132336	-2.502510E+07	3.354016E-03	3.415560E-04	4.955455E-06	4.364236E-07
3	3041	mat Q. with Bn = 3041K	3	-11.1334	3658.73	-102895	5.166520E+05	3.354016E-03	3.349290E-04	3.683843E-06	7.050455E-07
4	3136	mat R. with Bn = 3136K	3	-12.4493	4702.74	-402687	3.196830E+07	3.354016E-03	3.243880E-04	2.658012E-06	-2.701560E-07
5	3390	mat S. with Bn = 3390K	3	-12.6814	4391.97	-232807	1.509643E+07	3.354016E-03	2.993410E-04	2.135133E-06	-5.672000E-09
6	3528 ¹⁾	mat.I with Bn = 3528K	0.5	-12.0596	3687.667	-7617.13	-5.914730E+06	3.354016E-03	2.909670E-04	1.632136E-06	7.192200E-08
	3528 ²⁾			-21.0704	11903.95	-2504699	2.470338E+08	3.354016E-03	2.933908E-04	3.494314E-06	-7.712690E-07
7	3560	mat.H with Bn = 3560K	0.75	-13.0723	4190.574	-47158.4	-1.199256E+07	3.354016E-03	2.884193E-04	4.118032E-06	1.786790E-07
8	3740	mat.B with Bn = 3740K	2	-13.8973	4557.725	-98275	-7.522357E+06	3.354016E-03	2.744032E-04	3.666944E-06	1.375492E-07
9	3977	mat.A. with Bn = 3977K	0.75	-14.6337	4791.842	-115334	-3.730535E+06	3.354016E-03	2.569850E-04	2.620131E-06	6.383091E-08
10	4090	mat.C with Bn = 4090K	1.5	-15.5322	5229.973	-160451	-5.414091E+06	3.354016E-03	2.519107E-04	3.510939E-06	1.105179E-07
11	4190	mat.D with Bn = 4190K	1.5	-16.0349	5459.339	-191141	-3.328322E+06	3.354016E-03	2.460382E-04	3.405377E-06	1.034240E-07
12	4370	mat.E with Bn = 4370K	2.5	-16.8717	5759.15	-194267	-6.869149E+06	3.354016E-03	2.367720E-04	3.585140E-06	1.255349E-07
13	4570	mat.F with Bn = 4570K	1.5	-17.6439	6022.726	-203157	-7.183526E+06	3.354016E-03	2.264097E-04	3.278184E-06	1.097628E-07

Notes

1. Temperature < 25 °C
2. Temperature ≥ 25 °C



RESISTANCE VALUES AT INTERMEDIATE TEMPERATURES						
T _{OPER} (°C)	R _T /R ₂₅	ΔR DUE TO B-TOLERANCE (%)	TCR (%/K)	R ₂₅ (Ω)		
				2381 640; see note 1 at end of tables		
				6.338	6.478	6.688
- 40	13.6364	8.08	- 4.97	45.00	64.09	92.73
- 35	10.6806	7.30	- 4.80	35.25	50.20	72.63
- 30	8.4350	6.55	- 4.64	27.84	39.64	57.36
- 25	6.7148	5.84	- 4.48	22.16	31.56	45.66
- 20	5.3866	5.15	- 4.33	17.78	25.32	36.63
- 15	4.3532	4.49	- 4.19	14.37	20.46	29.60
- 10	3.5432	3.85	- 4.05	11.69	16.65	24.09
- 5	2.9035	3.24	- 3.92	9.58	13.65	19.74
0	2.3950	2.65	- 3.79	7.90	11.26	16.29
5	1.9880	2.08	- 3.66	6.56	9.34	13.52
10	1.6602	1.54	- 3.55	5.48	7.80	11.29
15	1.3944	1.01	- 3.43	4.60	6.55	9.48
20	1.1777	0.49	- 3.32	3.89	5.54	8.01
25	1.0000	0.00	- 3.22	3.30	4.70	6.80
30	0.8534	0.48	- 3.12	2.82	4.01	5.80
35	0.7319	0.94	- 3.02	2.42	3.44	4.98
40	0.6307	1.39	- 2.93	2.08	2.96	4.29
45	0.5459	1.82	- 2.84	1.80	2.57	3.71
50	0.4746	2.24	- 2.76	1.57	2.23	3.23
55	0.4143	2.65	- 2.68	1.37	1.95	2.82
60	0.3631	3.04	- 2.60	1.20	1.71	2.47
65	0.3194	3.43	- 2.52	1.05	1.50	2.17
70	0.2820	3.80	- 2.45	0.93	1.33	1.92
75	0.2499	4.16	- 2.38	0.82	1.17	1.70
80	0.2222	4.51	- 2.32	0.73	1.04	1.51
85	0.1982	4.85	- 2.25	0.65	0.93	1.35
90	0.1774	5.19	- 2.19	0.59	0.83	1.21
95	0.1592	5.51	- 2.13	0.53	0.75	1.08
100	0.1433	5.82	- 2.07	0.47	0.67	0.97
105	0.1294	6.13	- 2.02	0.43	0.61	0.88
110	0.1171	6.43	- 1.97	0.39	0.55	0.80
115	0.1063	6.72	- 1.92	0.35	0.50	0.72
120	0.0967	7.00	- 1.87	0.32	0.45	0.66
125	0.0882	7.28	- 1.82	0.29	0.41	0.60
130	0.0806	7.55	- 1.77	0.27	0.38	0.55
135	0.0739	7.81	- 1.73	0.24	0.35	0.50
140	0.0678	8.07	- 1.69	0.22	0.32	0.46
145	0.0624	8.32	- 1.65	0.21	0.29	0.42
150	0.0575	8.56	- 1.61	0.19	0.27	0.39

RESISTANCE VALUES AT INTERMEDIATE TEMPERATURES						
T _{OPER} (°C)	R _T /R ₂₅	ΔR DUE TO B-TOLERANCE (%)	TCR (%/K)	R ₂₅ (Ω)		
				2381 640; see note 1 at end of tables		
				6.109		
- 40	13.675	8.39	- 4.86	136.75		
- 35	10.763	7.58	- 4.72	107.63		
- 30	8.5318	6.81	- 4.58	85.32		
- 25	6.8097	6.06	- 4.44	68.10		
- 20	5.4717	5.35	- 4.31	54.72		
- 15	4.4253	4.66	- 4.18	44.25		
- 10	3.6017	4.00	- 4.06	36.02		
- 5	2.9494	3.37	- 3.94	29.49		



RESISTANCE VALUES AT INTERMEDIATE TEMPERATURES				
T _{OPER} (°C)	R _T /R ₂₅	ΔR DUE TO B-TOLERANCE (%)	TCR (%/K)	R ₂₅ (Ω)
				2381 640; see note 1 at end of tables
				6.109
0	2.4295	2.75	- 3.82	24.30
5	2.0128	2.16	- 3.71	20.13
10	1.6767	1.59	- 3.60	16.77
15	1.4042	1.04	- 3.50	14.04
20	1.1821	0.51	- 3.39	11.82
25	1.0000	0.00	- 3.30	10.00
30	0.8500	0.50	- 3.20	8.50
35	0.7259	0.98	- 3.11	7.26
40	0.6226	1.44	- 3.03	6.23
45	0.5363	1.89	- 2.94	5.36
50	0.4639	2.33	- 2.86	4.64
55	0.4029	2.75	- 2.78	4.03
60	0.3512	3.16	- 2.71	3.51
65	0.3073	3.56	- 2.64	3.07
70	0.2698	3.95	- 2.57	2.70
75	0.2377	4.32	- 2.50	2.38
80	0.2101	4.69	- 2.43	2.10
85	0.1864	5.04	- 2.37	1.86
90	0.1658	5.38	- 2.31	1.66
95	0.1479	5.72	- 2.25	1.48
100	0.1323	6.05	- 2.20	1.32
105	0.1187	6.36	- 2.14	1.19
110	0.1068	6.67	- 2.09	1.07
115	0.0964	6.98	- 2.04	0.96
120	0.0871	7.27	- 1.99	0.87
125	0.0790	7.56	- 1.94	0.79
130	0.0717	7.84	- 1.90	0.72
135	0.0653	8.11	- 1.85	0.65
140	0.0596	8.37	- 1.81	0.60
145	0.0545	8.63	- 1.77	0.55
150	0.0500	8.89	- 1.73	0.50

RESISTANCE VALUES AT INTERMEDIATE TEMPERATURES				
T _{OPER} (°C)	R _T /R ₂₅	ΔR DUE TO B-TOLERANCE (%)	TCR (%/K)	R ₂₅ (Ω)
				2381 640; see note 1 at end of tables
				6.159
- 40	14.9855	8.65	- 5.16	224.78
- 35	11.6319	7.79	- 4.98	174.47
- 30	9.1099	6.98	- 4.80	136.65
- 25	7.1957	6.21	- 4.64	107.93
- 20	5.7297	5.47	- 4.48	85.94
- 15	4.5975	4.76	- 4.33	68.96
- 10	3.7160	4.08	- 4.19	55.74
- 5	3.0245	3.43	- 4.05	45.37
0	2.4780	2.81	- 3.92	37.17
5	2.0431	2.20	- 3.80	30.65
10	1.6947	1.62	- 3.68	25.42
15	1.4138	1.06	- 3.57	21.21
20	1.1859	0.52	- 3.46	17.79
25	1.0000	0.00	- 3.36	15.00
30	0.8506	0.49	- 3.26	12.76
35	0.7242	0.98	- 3.17	10.86
40	0.6194	1.46	- 3.08	9.29



RESISTANCE VALUES AT INTERMEDIATE TEMPERATURES				
T _{OPER} (°C)	R _T /R ₂₅	ΔR DUE TO B-TOLERANCE (%)	TCR (%/K)	R ₂₅ (Ω)
				2381 640; see note 1 at end of tables
				6.159
45	0.5322	1.92	- 2.99	7.98
50	0.4591	2.36	- 2.91	6.89
55	0.3978	2.79	- 2.83	5.97
60	0.3459	3.21	- 2.75	5.19
65	0.3020	3.62	- 2.68	4.53
70	0.2645	4.02	- 2.61	3.97
75	0.2326	4.41	- 2.54	3.49
80	0.2051	4.78	- 2.48	3.08
85	0.1815	5.15	- 2.41	2.72
90	0.1611	5.51	- 2.35	2.42
95	0.1434	5.85	- 2.30	2.15
100	0.1280	6.19	- 2.24	1.92
105	0.1146	6.53	- 2.19	1.72
110	0.1029	6.85	- 2.13	1.54
115	0.0926	7.17	- 2.08	1.39
120	0.0835	7.48	- 2.03	1.25
125	0.0755	7.78	- 1.99	1.13
130	0.0684	8.08	- 1.94	1.03
135	0.0622	8.37	- 1.90	0.93
140	0.0566	8.65	- 1.86	0.85
145	0.0516	8.93	- 1.82	0.77
150	0.0472	9.20	- 1.78	0.71

RESISTANCE VALUES AT INTERMEDIATE TEMPERATURES				
T _{OPER} (°C)	R _T /R ₂₅	ΔR DUE TO B-TOLERANCE (%)	TCR (%/K)	R ₂₅ (Ω)
				2381 640; see note 1 at end of tables
				6.229
- 40	17.042	8.80	- 5.54	374.92
- 35	12.993	7.95	- 5.31	285.85
- 30	10.017	7.14	- 5.10	220.38
- 25	7.8037	6.36	- 4.90	171.68
- 20	6.1382	5.61	- 4.71	135.04
- 15	4.8719	4.89	- 4.53	107.18
- 10	3.8996	4.20	- 4.37	85.79
- 5	3.1461	3.53	- 4.22	69.21
0	2.5571	2.89	- 4.07	56.26
5	2.0930	2.27	- 3.94	46.05
10	1.7245	1.67	- 3.81	37.94
15	1.4298	1.10	- 3.69	31.45
20	1.1924	0.54	- 3.57	26.23
25	1.0000	0.00	- 3.47	22.00
30	0.8431	0.52	- 3.36	18.55
35	0.7144	1.02	- 3.26	15.72
40	0.6083	1.51	- 3.17	13.38
45	0.5203	1.98	- 3.08	11.45
50	0.4470	2.44	- 3.00	9.83
55	0.3856	2.88	- 2.92	8.48
60	0.3339	3.32	- 2.84	7.35
65	0.2903	3.73	- 2.76	6.39
70	0.2533	4.14	- 2.69	5.57
75	0.2218	4.53	- 2.62	4.88
80	0.1948	4.91	- 2.56	4.29



RESISTANCE VALUES AT INTERMEDIATE TEMPERATURES				
T _{OPER} (°C)	R _T /R ₂₅	ΔR DUE TO B-TOLERANCE (%)	TCR (%/K)	R ₂₅ (Ω)
				2381 640; see note 1 at end of tables
				6.229
85	0.1717	5.29	- 2.50	3.78
90	0.1518	5.65	- 2.44	3.34
95	0.1346	6.00	- 2.38	2.96
100	0.1196	6.34	- 2.32	2.63
105	0.1067	6.68	- 2.27	2.35
110	0.0954	7.00	- 2.22	2.10
115	0.0855	7.32	- 2.17	1.88
120	0.0768	7.62	- 2.12	1.69
125	0.0691	7.93	- 2.07	1.52
130	0.0624	8.22	- 2.03	1.37
135	0.0565	8.50	- 1.98	1.24
140	0.0512	8.78	- 1.94	1.13
145	0.0165	9.06	- 1.90	1.02
150	0.0423	9.32	- 1.86	0.93

RESISTANCE VALUES AT INTERMEDIATE TEMPERATURES						
T _{OPER} (°C)	R _T /R ₂₅	ΔR DUE TO B-TOLERANCE (%)	TCR (%/K)	R ₂₅ (Ω)		
				2381 640; see note 1 at end of tables		
				6.339	6.479	6.689
- 40	21.4241	9.51	- 5.94	707.00	1006.93	1456.84
- 35	16.0147	8.59	- 5.70	528.48	752.69	1089.00
- 30	12.1074	7.72	- 5.49	399.54	569.05	823.30
- 25	9.2511	6.87	- 5.28	305.29	434.80	629.07
- 20	7.1395	6.06	- 5.09	235.60	335.56	485.49
- 15	5.5619	5.29	- 4.90	183.54	261.41	378.21
- 10	4.3715	4.54	- 4.73	144.26	205.46	297.26
- 5	3.4647	3.82	- 4.57	114.33	162.84	235.60
0	2.7678	3.12	- 4.42	91.34	130.09	188.21
5	2.2276	2.45	- 4.27	73.51	104.70	151.48
10	1.8057	1.81	- 4.13	59.59	84.87	122.79
15	1.4735	1.18	- 4.00	48.63	69.26	100.20
20	1.2102	0.58	- 3.88	39.94	56.88	82.29
25	1.0000	0.00	- 3.76	33.00	47.00	68.00
30	0.8311	0.56	- 3.64	27.43	39.06	56.51
35	0.6946	1.11	- 3.54	22.92	32.64	47.23
40	0.5835	1.63	- 3.43	19.26	27.42	39.68
45	0.4927	2.14	- 3.34	16.26	23.16	33.50
50	0.4180	2.64	- 3.24	13.79	19.65	28.42
55	0.3563	3.12	- 3.15	11.76	16.74	24.23
60	0.3050	3.58	- 3.07	10.06	14.33	20.74
65	0.2622	4.03	- 2.98	8.65	12.32	17.83
70	.02263	4.47	- 2.90	7.47	10.64	15.39
75	0.1961	4.90	- 2.83	6.47	9.22	13.33
80	0.1705	5.31	- 2.76	5.63	8.02	11.60
85	0.1489	5.71	- 2.69	4.91	7.00	10.12
90	0.1304	6.11	- 2.62	4.30	6.13	8.86
95	0.1146	6.49	- 2.55	3.78	5.38	7.79
100	0.1010	6.86	- 2.49	3.33	4.75	6.87
105	0.0893	7.22	- 2.43	2.95	4.20	6.07
110	0.0792	7.57	- 2.37	2.61	3.72	5.38
115	0.0704	7.91	- 2.32	2.32	3.31	4.79
120	0.0628	8.24	- 2.26	2.07	2.95	4.27
125	0.0561	8.57	- 2.21	1.85	2.64	3.82



2381 640 3/4/6..../NTCLE100E3...B0/T1/T2

NTC Thermistors, Accuracy Line

Vishay BCcomponents

RESISTANCE VALUES AT INTERMEDIATE TEMPERATURES						
T _{OPER} (°C)	R _T /R ₂₅	ΔR DUE TO B-TOLERANCE (%)	TCR (%/K)	R ₂₅ (Ω)		
				2381 640; see note 1 at end of tables		
				6.339	6.479	6.689
130	0.0503	8.88	- 2.16	1.66	2.37	3.42
135	0.0452	9.19	- 2.11	1.49	2.13	3.07
140	0.0407	9.49	- 2.07	1.34	1.91	2.77
145	0.0368	9.79	- 2.02	1.21	1.73	2.50
150	0.0333	10.08	- 1.98	1.10	1.56	2.26

RESISTANCE VALUES AT INTERMEDIATE TEMPERATURES									
T _{OPER} (°C)	R _T /R ₂₅	ΔR DUE TO B-TOLERANCE (%)	TCR (%/K)	R ₂₅ (Ω)					
				2381 640; see note 1 AT END OF TABLES					
				6.101	6.151	6.221	6.331	6.471	6.681
- 40	21.9261	2.50	- 5.75	2192.6	2388.9	4823.7	7236	10503	14910
- 35	16.5224	2.26	- 5.57	1652.2	2478.4	3634.9	5452	7766	11235
- 30	12.5583	2.03	- 5.40	1255.8	1883.7	2762.8	4144	5902	8540
- 25	9.62492	1.80	- 5.24	962.5	1443.7	2117.5	3176	4524	6545
- 20	7.43618	1.59	- 5.08	743.6	1115.4	1636.0	2454	3495	5057
- 15	5.78976	1.39	- 4.93	579.0	868.5	1273.7	1911	2721	3937
- 10	4.54158	1.19	- 4.78	454.2	681.2	999.1	1499	1235	3088
- 5	3.58813	1.00	- 4.64	358.8	538.2	789.4	1184	1686	2440
0	2.85449	0.82	- 4.51	285.4	428.2	628.0	942.0	1342	1941
5	2.28599	0.64	- 4.38	228.6	342.9	502.9	754.4	1074	1554
10	1.84245	0.47	- 4.25	184.2	276.4	405.3	608.0	865.9	1253
15	1.49414	0.31	- 4.13	149.4	224.1	328.7	493.1	702.2	1016
20	1.21887	0.15	- 4.01	121.9	182.8	268.2	402.2	572.9	828.8
25	1.000	0.00	- 3.90	100.0	150.0	220.0	330.0	470.0	680.0
30	0.82494	0.15	- 3.80	82.5	123.7	181.5	272.2	387.7	561.0
35	0.68413	0.29	- 3.69	68.4	102.6	150.5	225.8	321.5	465.2
40	0.57025	0.43	- 3.59	57.0	85.5	125.5	188.2	268.0	387.8
45	0.47765	0.56	- 3.50	47.8	71.6	105.1	157.6	224.5	324.8
50	0.40198	0.69	- 3.40	40.2	60.3	88.4	132.7	188.9	273.3
55	0.33984	0.82	- 3.31	34.0	51.0	74.8	112.1	159.7	231.1
60	0.28856	0.94	- 3.23	28.9	43.3	63.5	95.23	135.6	196.2
65	0.24606	1.06	- 3.15	24.6	36.9	54.1	81.20	115.6	167.3
70	0.21067	1.17	- 3.07	21.1	31.6	46.3	69.52	99.00	143.3
75	0.18108	1.29	- 2.99	18.1	27.2	39.8	59.76	85.11	123.1
80	0.15623	1.39	- 2.91	15.6	23.4	34.4	51.56	73.43	106.2
85	0.13529	1.50	- 2.84	13.5	20.3	29.8	44.65	63.59	92.00
90	0.11757	1.60	- 2.77	11.8	17.6	25.9	38.80	55.26	79.95
95	0.10251	1.70	- 2.71	10.3	15.4	22.6	33.83	48.18	69.71
100	0.08968	1.80	- 2.64	8.97	13.5	19.7	29.59	42.15	60.98
105	0.07871	1.89	- 2.58	7.87	11.8	17.3	25.97	36.99	53.52
110	0.06928	1.99	- 2.52	6.93	10.4	15.2	22.86	32.56	47.11
115	0.06117	2.08	- 2.46	6.12	9.18	13.5	20.19	28.75	41.60
120	0.05416	2.16	- 2.41	5.42	8.12	11.9	17.87	25.46	36.83
125	0.04809	2.25	- 2.35	4.81	7.21	10.6	15.87	22.60	32.70
130	0.04282	2.33	- 2.30	4.28	6.42	9.42	14.13	20.12	29.11
135	0.03822	2.41	- 2.25	3.82	5.73	8.41	12.61	17.96	25.99
140	0.03420	2.49	- 2.20	3.42	5.13	7.52	11.29	16.07	23.25
145	0.03068	2.57	- 2.15	3.07	4.60	6.75	10.12	14.42	20.86
150	0.02758	2.65	- 2.10	2.76	4.14	6.07	9.10	12.96	18.76



RESISTANCE VALUES AT INTERMEDIATE TEMPERATURES						
T _{OPER} (°C)	R _T /R ₂₅	ΔR DUE TO B-TOLERANCE (%)	TCR (%/K)	R ₂₅ (Ω)		
				2381 640; see note 1 at end of tables		
				6.102	6.152	6.202
- 40	23.3402	1.65	- 6.06	23342	35013	46684
- 35	17.3347	1.49	- 5.84	17336	26004	34672
- 30	13.0166	1.34	- 5.62	13018	19526	26035
- 25	9.8764	1.19	- 5.42	9877	14816	19754
- 20	7.5682	1.05	- 5.23	7569	11353	15138
- 15	5.8541	0.92	- 5.05	5855	8782	11709
- 10	4.5688	0.79	- 4.87	4569	6854	9138
- 5	3.5961	0.66	- 4.71	3596	5395	7193
0	2.8533	0.54	- 4.55	2854	4280	5707
5	2.2815	0.43	- 4.40	2282	3422	4563
10	1.8376	0.31	- 4.26	1838	2457	3675
15	1.4904	0.21	- 4.12	1491	2236	2981
20	1.2169	0.10	- 3.99	1217	1826	2434
25	1.0000	0.00	- 3.87	1000	1500	2000
30	0.8266	0.10	- 3.75	826.7	1240	1653
35	0.6873	0.19	- 3.63	687.4	1031	1375
40	0.5746	0.28	- 3.53	574.6	861.9	1149
45	0.4827	0.37	- 3.42	482.7	724.1	965.0
50	0.4073	0.46	- 3.32	407.4	611.0	814.7
55	0.3452	0.54	- 3.23	345.2	517.8	690.5
60	0.2937	0.62	- 3.14	293.7	440.6	587.5
65	0.2508	0.70	- 3.05	250.8	376.2	501.7
70	0.2149	0.78	- 2.97	214.9	322.4	429.8
75	0.1847	0.85	- 2.89	184.8	277.1	369.5
80	0.1593	0.92	- 2.81	159.3	238.9	318.6
85	0.1377	0.99	- 2.73	137.7	206.6	275.5
90	0.11942	1.06	- 2.66	119.4	179.1	238.9
95	0.10380	1.13	- 2.59	103.8	155.7	207.6
100	0.09045	1.19	- 2.53	90.46	135.7	180.9
105	0.07900	1.25	- 2.46	79.00	118.5	158.0
110	0.06915	1.31	- 2.40	69.16	103.7	138.3
115	0.06066	1.37	- 2.34	60.66	90.99	121.3
120	0.05332	1.43	- 2.29	53.32	79.98	106.6
125	0.04696	1.49	- 2.23	46.96	70.44	93.9
130	0.04143	1.54	- 2.18	41.44	62.15	82.9
135	0.03662	1.60	- 2.13	36.63	54.94	73.3
140	0.03243	1.65	- 2.08	32.43	48.65	64.9
145	0.02877	1.70	- 2.03	28.77	43.16	57.5
150	0.02556	1.75	- 1.98	25.56	38.34	51.1

RESISTANCE VALUES AT INTERMEDIATE TEMPERATURES									
T _{OPER} (°C)	R _T /R ₂₅	ΔR DUE TO B-TOLERANCE (%)	TCR (%/K)	R ₂₅ (kΩ)					
				2381 640; see note 1 at end of tables					
				6.222	6.272	6.332	6.472	6.682	6.103
- 40	33.21	2.66	6.57	73.06	89.67	109.6	156.1	225.8	332.1
- 35	23.99	2.41	6.36	52.78	64.77	79.17	112.8	163.1	240.0
- 30	17.52	2.17	6.15	38.55	47.31	57.82	82.35	119.1	175.2
- 25	12.93	1.94	5.95	28.44	34.91	42.67	60.77	87.92	129.3
- 20	9.636	1.71	5.76	21.20	26.02	31.80	45.30	65.53	96.36
- 15	7.250	1.50	5.58	15.95	19.58	23.93	34.08	49.30	72.50
- 10	5.505	1.29	5.40	12.11	14.86	18.16	25.87	37.43	55.05
- 5	4.216	1.08	5.24	9.275	11.38	13.91	19.81	28.67	42.16
0	3.255	0.89	5.08	7.162	8.790	10.74	15.30	22.14	32.56



2381 640 3/4/6.../NTCLE100E3...B0/T1/T2

NTC Thermistors, Accuracy Line

Vishay BCcomponents

RESISTANCE VALUES AT INTERMEDIATE TEMPERATURES									
T _{OPER} (°C)	R _T /R ₂₅	ΔR DUE TO B-TOLERANCE (%)	TCR (%/K)	R ₂₅ (kΩ)					
				2381 640; see note 1 at end of tables					
				6.222	6.272	6.332	6.472	6.682	6.103
5	2.534	0.70	4.92	5.575	6.842	8.362	11.91	17.23	25.34
10	1.987	0.52	4.78	4.372	5.366	6.558	9.340	13.51	19.87
15	1.570	0.34	4.64	3.454	4.239	5.181	7.378	10.67	15.70
20	1.249	0.17	4.50	2.747	3.372	4.121	5.869	8.492	12.49
25	1.000	0.00	4.37	2.200	2.700	3.300	4.700	6.800	10.00
30	0.8059	0.16	4.25	1.773	2.176	2.660	3.788	5.480	8.059
35	0.6535	0.32	4.13	1.438	1.764	2.156	3.072	4.444	6.535
40	0.5330	0.47	4.02	1.173	1.439	1.759	2.505	3.624	5.330
45	0.4372	0.62	3.91	0.9618	1.180	1.443	2.055	2.972	4.372
50	0.3605	0.77	3.80	0.7932	0.973	1.190	1.694	2.451	3.606
55	0.2989	0.91	3.70	0.6575	0.807	0.9863	1.405	2.032	2.989
60	0.2490	1.05	3.60	0.5478	0.672	0.8217	1.170	1.693	2.490
65	0.2084	1.18	3.51	0.4586	0.562	0.6879	0.9797	1.417	2.084
70	0.1753	1.31	3.42	0.3857	0.473	0.5785	0.8239	1.192	1.753
75	0.1481	1.44	3.33	0.3258	0.399	0.4887	0.6960	1.007	1.481
80	0.1256	1.57	3.25	0.2764	0.339	0.4146	0.5905	0.8544	1.256
85	0.1070	1.69	3.16	0.2355	0.289	0.3532	0.5031	0.7278	1.070
90	0.09154	1.81	3.09	0.2014	0.247	0.3021	0.4303	0.6225	0.9154
95	0.07860	1.93	3.01	0.1729	0.212	0.2594	0.3694	0.5345	0.7860
100	0.06773	2.04	2.94	0.1490	0.182	0.2235	0.3183	0.4607	0.6773
105	0.05858	2.15	2.87	0.1289	0.158	0.1933	0.2753	0.3983	0.5858
110	0.05083	2.26	2.80	0.1118	0.137	0.1677	0.2389	0.3457	0.5083
115	0.04426	2.37	2.73	0.0974	0.1195	0.1461	0.2080	0.3010	0.4426
120	0.03866	2.47	2.67	0.0851	0.1044	0.1276	0.1817	0.2629	0.3866
125	0.03387	2.57	2.61	0.0745	0.0915	0.1118	0.1592	0.2303	0.3387
130	0.02977	2.67	2.55	0.0655	0.0804	0.0982	0.1399	0.2024	0.2977
135	0.02624	2.77	2.49	0.0577	0.0709	0.0866	0.1233	0.1784	0.2624
140	0.02319	2.86	2.43	0.0510	0.0626	0.0765	0.1090	0.1577	0.2319
145	0.02055	2.96	2.38	0.0452	0.0555	0.0678	0.0966	0.1398	0.2055
150	0.01826	3.05	2.33	0.0402	0.0493	0.0603	0.0858	0.1242	0.1826

RESISTANCE VALUES AT INTERMEDIATE TEMPERATURES						
T _{OPER} (°C)	R _T /R ₂₅	ΔR DUE TO B-TOLERANCE (%)	TCR (%/K)	R ₂₅ (Ω)		
				2381 640; see note 1 at end of tables		
				6.123	6.153	6.223
- 40	25.78	6.81	6.09	309.4	386.8	567.2
- 35	19.13	6.16	5.89	229.5	286.9	420.8
- 30	14.32	5.53	5.70	171.8	214.8	315.0
- 25	10.82	4.93	5.52	129.8	162.3	238.0
- 20	8.245	4.35	5.35	98.93	123.7	181.4
- 15	6.335	3.80	5.19	76.02	95.03	139.4
- 10	4.907	3.26	5.03	58.88	73.60	107.9
- 5	3.830	2.74	4.88	45.95	57.44	84.25
0	3.011	2.24	4.73	36.13	45.16	66.24
5	2.384	1.76	4.60	28.60	35.76	52.45
10	1.900	1.30	4.46	22.80	28.50	41.81
15	1.525	0.85	4.34	18.30	22.87	33.55
20	1.231	0.42	4.21	14.77	18.47	27.09
25	1.000	0.00	4.10	12.00	15.00	22.00
30	0.8170	0.41	3.98	9.804	12.26	17.97
35	0.6712	0.80	3.88	8.054	10.07	14.77
40	0.5543	1.19	3.77	6.652	8.315	12.20



RESISTANCE VALUES AT INTERMEDIATE TEMPERATURES						
T _{OPER} (°C)	R _T /R ₂₅	ΔR DUE TO B-TOLERANCE (%)	TCR (%/K)	R ₂₅ (Ω)		
				2381 640; see note 1 at end of tables		
				6.123	6.153	6.223
45	0.4602	1.57	3.67	5.522	6.903	10.12
50	0.3839	1.94	3.57	4.607	5.759	8.447
55	0.3219	2.30	3.48	3.862	4.828	7.081
60	0.2710	2.65	3.39	3.252	4.067	5.963
65	0.2293	2.99	3.30	2.751	3.439	5.044
70	0.1947	3.33	3.22	2.337	2.921	4.284
75	0.1661	3.66	3.14	1.993	2.492	3.654
80	0.1422	3.98	3.06	1.707	2.134	3.129
85	0.1223	4.29	2.99	1.467	1.834	2.690
90	0.1055	4.60	2.92	1.266	1.583	2.321
95	0.09135	4.90	2.85	1.096	1.370	2.010
100	0.07937	5.19	2.78	0.9524	1.190	1.746
105	0.06919	5.48	2.71	0.8302	1.038	1.522
110	0.06050	5.76	2.65	0.7260	0.9075	1.331
115	0.05307	6.04	2.59	0.6369	0.7961	1.168
120	0.04670	6.31	2.53	0.5604	0.7005	1.027
125	0.04121	6.57	2.47	0.4945	0.6181	0.9065

RESISTANCE VALUES AT INTERMEDIATE TEMPERATURES						
T _{OPER} (°C)	R _T /R ₂₅	ΔR DUE TO B-TOLERANCE (%)	TCR (%/K)	R ₂₅ (kΩ)		
				2381 640; see note 1 at end of tables		
				6.333	6.473	
- 40	33.81	5.55	6.55	1116	1589	
- 35	24.50	5.02	6.34	808.6	1151	
- 30	17.93	4.52	6.15	591.7	842.8	
- 25	13.25	4.03	5.96	437.1	622.6	
- 20	9.875	3.56	5.78	325.9	464.1	
- 15	7.425	3.10	5.61	245.0	349.0	
- 10	5.630	2.67	5.45	185.8	264.6	
- 5	4.304	2.24	5.29	142.0	202.3	
0	3.315	1.84	5.14	109.4	155.8	
5	2.573	1.44	4.99	84.91	120.9	
10	2.011	1.07	4.85	66.37	94.53	
15	1.583	0.70	4.72	52.24	74.40	
20	1.254	0.34	4.59	41.39	58.95	
25	1.000	0.00	4.46	33.00	47.00	
30	0.8024	0.33	4.34	26.47	37.71	
35	0.6474	0.66	4.23	21.37	30.43	
40	0.5255	0.98	4.12	17.34	24.70	
45	0.4288	1.28	4.01	14.15	20.15	
50	0.3518	1.59	3.91	11.61	16.53	
55	0.2901	1.88	3.81	9.572	13.63	
60	0.2403	2.17	3.71	7.931	11.30	
65	0.2001	2.45	3.62	6.603	9.404	
70	0.1674	2.72	3.53	5.522	7.865	
75	0.1406	2.99	3.44	4.639	6.607	
80	0.1186	3.25	3.36	3.913	5.573	
85	0.1004	3.51	3.28	3.315	4.721	
90	0.08542	3.76	3.20	2.819	4.015	
95	0.07292	4.00	3.13	2.406	3.427	
100	0.06248	4.24	3.06	2.062	2.936	
105	0.05372	4.47	2.98	1.773	2.525	
110	0.04635	4.70	2.92	1.530	2.179	



RESISTANCE VALUES AT INTERMEDIATE TEMPERATURES						
T _{OPER} (°C)	R _T /R ₂₅	ΔR DUE TO B-TOLERANCE (%)	TCR (%/K)	R ₂₅ (kΩ)		
				2381 640; see note 1 at end of tables		
				6.333	6.473	
115	0.04013	4.93	2.85	1.342	1.886	
120	0.03485	5.15	2.79	1.150	1.638	
125	0.03037	5.36	2.73	1.002	1.427	
130	0.02654	5.57	2.67	0.8757	1.247	
135	0.02326	5.78	2.61	0.7675	1.093	
140	0.02044	5.98	2.55	0.6746	0.9608	
145	0.01802	6.18	2.50	0.5945	0.8468	
150	0.01592	6.37	2.44	0.5254	0.7483	

RESISTANCE VALUES AT INTERMEDIATE TEMPERATURES						
T _{OPER} (°C)	R _T /R ₂₅	ΔR DUE TO B-TOLERANCE (%)	TCR (%/K)	R ₂₅ (kΩ)		
				2381 640; see note 1 at end of tables		
				6.683	6.104	
- 40	36.66	5.69	6.70	2493	3666	
- 35	26.38	5.15	6.49	1794	2638	
- 30	19.17	4.63	6.29	1303	1917	
- 25	14.06	4.13	6.10	956.2	1406	
- 20	10.41	3.65	5.92	708.0	1041	
- 15	7.779	3.18	5.74	528.9	777.9	
- 10	5.861	2.73	5.57	398.5	586.1	
- 5	4.453	2.30	5.41	302.8	445.3	
0	3.409	1.88	5.26	231.8	340.9	
5	2.631	1.48	5.11	178.9	263.1	
10	2.044	1.09	4.97	139.0	204.4	
15	1.600	0.72	4.83	108.8	160.0	
20	1.261	0.35	4.70	85.74	126.1	
25	1.000	0.00	4.57	68.00	100.0	
30	0.7981	0.34	4.45	54.27	79.81	
35	0.6408	0.67	4.35	43.57	64.08	
40	0.5175	1.00	4.22	35.19	51.74	
45	0.4202	1.32	4.11	28.57	42.02	
50	0.3431	1.63	4.00	23.33	34.31	
55	0.2816	1.93	3.90	19.15	28.16	
60	0.2322	2.22	3.80	15.79	23.22	
65	0.1925	2.51	3.71	13.09	19.25	
70	0.1602	2.79	3.62	10.90	16.03	
75	0.1340	3.06	3.53	9.114	13.40	
80	0.1126	3.33	3.45	7.655	11.26	
85	0.09496	3.59	3.36	6.457	9.496	
90	0.08042	3.85	3.28	5.469	8.042	
95	0.06837	4.10	3.21	4.649	6.837	
100	0.05835	4.35	3.13	3.968	5.835	
105	0.04998	4.59	3.06	3.399	4.998	
110	0.04296	4.82	2.99	2.921	4.296	
115	0.03705	5.05	2.92	2.519	3.705	
120	0.03206	5.28	2.86	2.180	3.206	
125	0.02783	5.50	2.80	1.892	2.783	



RESISTANCE VALUES AT INTERMEDIATE TEMPERATURES					
T _{OPER} (°C)	R _T /R ₂₅	ΔR DUE TO B-TOLERANCE (%)	TCR (%/K)	R ₂₅ (kΩ)	
				2381 640; see note 1 at end of tables	
				6.154	6.224
- 40	41.02	10.10	6.89	6153	9024
- 35	29.29	9.12	6.68	4394	6444
- 30	21.12	8.18	6.48	3168	4646
- 25	15.37	7.28	6.29	2305	3381
- 20	11.28	6.42	6.11	1693	2483
- 15	8.358	5.59	5.93	1254	1839
- 10	6.242	4.80	5.76	936.4	1373
- 5	4.700	4.03	5.60	705.0	1034
0	3.567	3.30	5.44	535.0	784.7
5	2.727	2.59	5.29	409.1	600.0
10	2.101	1.90	5.15	315.1	462.1
15	1.629	1.25	5.01	244.4	358.4
20	1.272	0.61	4.88	190.8	279.9
25	1.000	0.00	4.75	150.0	220.0
30	0.7910	0.59	4.62	118.6	174.0
35	0.6295	1.18	4.51	94.42	138.5
40	0.5039	1.74	4.39	75.58	110.9
45	0.4056	2.30	4.28	60.85	89.24
50	0.3283	2.84	4.17	49.25	72.24
55	0.2672	3.37	4.07	40.08	58.78
60	0.2185	3.89	3.97	32.78	48.08
65	0.1796	4.40	3.87	26.94	39.51
70	0.1483	4.90	3.78	22.25	32.63
75	0.1231	5.39	3.69	18.46	27.07
80	0.1025	5.86	3.60	15.38	22.56
85	0.08582	6.33	3.52	12.87	18.88
90	0.07213	6.79	3.44	10.82	15.87
95	0.06086	7.24	3.36	9.129	13.39
100	0.05155	7.68	3.28	7.732	11.34
105	0.04383	8.11	3.21	6.574	9.642
110	0.03740	8.53	3.14	5.610	8.228
115	0.03203	8.94	3.07	4.804	7.046
120	0.02752	9.35	3.00	4.128	6.054
125	0.02372	9.75	2.94	3.559	5.219

RESISTANCE VALUES AT INTERMEDIATE TEMPERATURES					
T _{OPER} (°C)	R _T /R ₂₅	ΔR DUE TO B-TOLERANCE (%)	TCR (%/K)	R ₂₅ (kΩ)	
				2381 640; see note 1 at end of tables	
				6.334	6.474
- 40	48.62	6.22	7.13	16044	22850
- 35	34.19	5.63	6.91	11282	16068
- 30	24.28	5.06	6.71	8013	11413
- 25	17.42	4.51	6.52	5747	8185
- 20	12.61	3.98	6.33	4161	5926
- 15	9.211	3.47	6.15	3040	4329
- 10	6.788	2.98	5.98	2240	3190
- 5	5.045	2.51	5.82	1665	2371
0	3.781	2.06	5.66	1248	1776
5	2.855	1.62	5.50	942.3	1342
10	2.173	1.19	5.36	717.1	1021
15	1.666	0.78	5.22	549.8	783.0
20	1.286	0.38	5.08	424.5	604.6
25	1.000	0.00	4.95	330.0	470.0



2381 640 3/4/6.../NTCLE100E3...B0/T1/T2

NTC Thermistors, Accuracy Line

Vishay BCcomponents

RESISTANCE VALUES AT INTERMEDIATE TEMPERATURES					
T_{OPER} (°C)	R_T/R_{25}	ΔR DUE TO B-TOLERANCE (%)	TCR (%/K)	R_{25} (k Ω)	
				2381 640; see note 1 at end of tables	
				6.334	6.474
30	0.7825	0.37	4.82	258.2	367.8
35	0.6163	0.74	4.70	203.4	289.6
40	0.4883	1.09	4.59	161.1	229.5
45	0.3892	1.44	4.47	128.4	182.9
50	0.3120	1.77	4.36	103.0	146.7
55	0.2515	2.10	4.26	83.00	118.2
60	0.2038	2.43	4.15	67.26	95.80
65	0.1660	2.74	4.06	54.79	78.03
70	0.1359	3.05	3.96	44.86	63.88
75	0.1118	3.35	3.87	36.90	52.55
80	0.09240	3.64	3.78	30.49	43.43
85	0.07670	3.93	3.69	25.31	36.05
90	0.06395	4.21	3.61	21.10	30.06
95	0.05354	4.48	3.53	17.67	25.16
100	0.04501	4.75	3.45	14.85	21.15
105	0.03798	5.01	3.37	12.53	17.85
110	0.03218	5.27	3.30	10.70	15.12
115	0.02736	5.52	3.23	9.029	12.86
120	0.02335	5.77	3.16	7.704	10.97
125	0.01999	6.01	3.09	6.597	9.396

RESISTANCE VALUES AT INTERMEDIATE TEMPERATURES WITH R_{25} AT 68 kΩ AND 100 kΩ					
T_{AMB} (°C)	R_T/R_{25}	ΔR DUE TO B-TOLERANCE (%)	TCR (%/K)	R_{25} (k Ω)	
				2381 640; see note 1 at end of tables	
				6.683	6.104
- 40	36.66	5.69	6.70	2493	3666
- 35	26.38	5.15	6.49	1794	2638
- 30	19.17	4.63	6.29	1303	1917
- 25	14.06	4.13	6.10	956.2	1406
- 20	10.41	3.65	5.92	708.0	1041
- 15	7.779	3.18	5.74	528.9	777.9
- 10	5.861	2.73	5.57	398.5	586.1
- 5	4.453	2.30	5.41	302.8	445.3
0	3.409	1.88	5.26	231.8	340.9
5	2.631	1.48	5.11	178.9	263.1
10	2.044	1.09	4.97	139.0	204.4
15	1.600	0.72	4.83	108.8	160.0
20	1.261	0.35	4.70	85.74	126.1
25	1.000	0.00	4.57	68.00	100.0
30	0.7981	0.34	4.45	54.27	79.81
35	0.6408	0.67	4.35	43.57	64.08
40	0.5175	1.00	4.22	35.19	51.74
45	0.4202	1.32	4.11	28.57	42.02
50	0.3431	1.63	4.00	23.33	34.31
55	0.2816	1.93	3.90	19.15	28.16
60	0.2322	2.22	3.80	15.79	23.22
65	0.1925	2.51	3.71	13.09	19.25
70	0.1602	2.79	3.62	10.90	16.03
75	0.1340	3.06	3.53	9.114	13.40
80	0.1126	3.33	3.45	7.655	11.26
85	0.09496	3.59	3.36	6.457	9.496
90	0.08042	3.85	3.28	5.469	8.042



RESISTANCE VALUES AT INTERMEDIATE TEMPERATURES WITH R₂₅ AT 68 kΩ AND 100 kΩ					
T _{AMB} (°C)	R _T /R ₂₅	ΔR DUE TO B-TOLERANCE (%)	TCR (%/K)	R ₂₅ (kΩ)	
				2381 640; see note 1 at end of tables	
				6.683	6.104
95	0.06837	4.10	3.21	4.649	6.837
100	0.05835	4.35	3.13	3.968	5.835
105	0.04998	4.59	3.06	3.399	4.998
110	0.04296	4.82	2.99	2.921	4.296
115	0.03705	5.05	2.92	2.519	3.705
120	0.03206	5.28	2.86	2.180	3.206
125	0.02783	5.50	2.80	1.892	2.783

RESISTANCE VALUES AT INTERMEDIATE TEMPERATURES WITH R₂₅ AT 470 kΩ					
T _{AMB} (°C)	R _T /R ₂₅	ΔR DUE TO B-TOLERANCE (%)	TCR (%/K)	R ₂₅ (kΩ)	
				2381 640; see note 1 at end of tables	
				5.474	
- 40	48.62	6.22	7.13	22850	
- 35	34.19	5.63	6.91	16068	
- 30	24.28	5.06	6.71	11413	
- 25	17.42	4.51	6.52	8185	
- 20	12.61	3.98	6.33	5926	
- 15	9.211	3.47	6.15	4329	
- 10	6.788	2.98	5.98	3190	
- 5	5.045	2.51	5.82	2371	
0	3.781	2.06	5.66	1776	
5	2.855	1.62	5.50	1342	
10	2.173	1.19	5.36	1021	
15	1.666	0.78	5.22	783.0	
20	1.286	0.38	5.08	604.6	
25	1.000	0.00	4.95	470.0	
30	0.7825	0.37	4.82	367.8	
35	0.6163	0.74	4.70	289.6	
40	0.4883	1.09	4.59	229.5	
45	0.3892	1.44	4.47	182.9	
50	0.3120	1.77	4.36	146.7	
55	0.2515	2.10	4.26	118.2	
60	0.2038	2.43	4.15	95.80	
65	0.1660	2.74	4.06	78.03	
70	0.1359	3.05	3.96	63.88	
75	0.1118	3.35	3.87	52.55	
80	0.09240	3.64	3.78	43.43	
85	0.07670	3.93	3.69	36.05	
90	0.06395	4.21	3.61	30.06	
95	0.05354	4.48	3.53	25.16	
100	0.04501	4.75	3.45	21.15	
105	0.03798	5.01	3.37	17.85	
110	0.03218	5.27	3.30	15.12	
115	0.02736	5.52	3.23	12.86	
120	0.02335	5.77	3.16	10.97	
125	0.01999	6.01	3.09	9.396	

Note to Resistance Values At Intermediate Temperature Tables

1. Replace dot in last 5 digits of catalog number by a number according to the following details and depending on tolerance on required R₂₅ - value: 4 for a tolerance of ± 2 %; 6 for a tolerance of ± 3 %; 3 for a tolerance of ± 5 %; 2 for a tolerance of ± 10 %.

PACKAGING

TAPE SPECIFICATIONS

Thermistors on tape

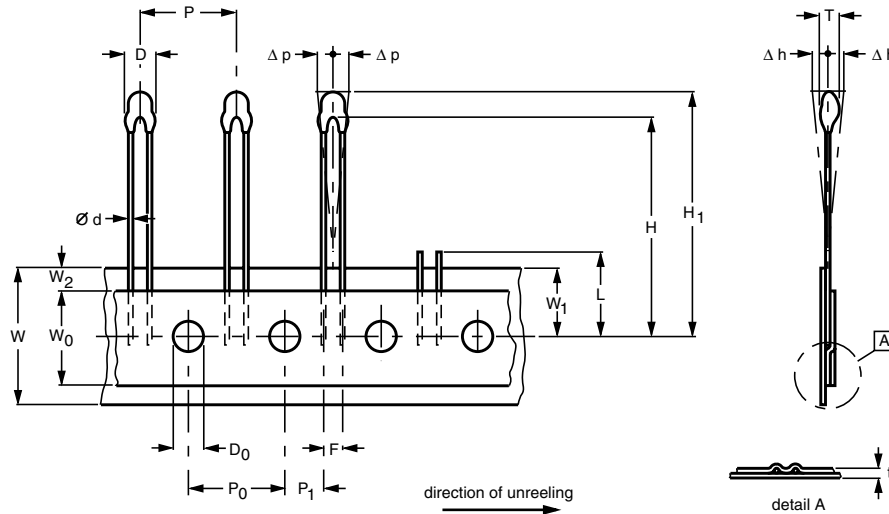

1E pitch
2322 640 4....

DIMENSIONS OF TAPE IN ACCORDANCE WITH "IEC 60286-2"			
SYMBOL	PARAMETER	DIMENSIONS (mm)	
		VALUE	TOLERANCE
D	body diameter ²⁾	3.3	± 0.5
T	maximum total thickness	≤ 3	-
d	lead diameter	0.6	± 0.06
P	pitch between thermistors	12.7	± 1
P ₀	feed-hole pitch (cumulative pitch error ± 0.2 mm/20 products)	12.7	± 0.3
P ₁	feed-hole centre to lead centre	5.08	± 0.7
Δp	component alignment	0	± 1.3
F	lead-to-lead distance	2.54	± 0.3
Δh	component alignment	0	± 2
W	tape width	18.0	+ 1/- 0.5
W ₀	hold-down tape width	≥ 12.5	-
W ₁	feed-hole position	9.0	± 0.5
W ₂	hold-down tape position	≤ 3	-
H	component to tape centre	22 ¹⁾	± 1
H ₁	component height	≤ 32	-
L	length of snapped lead	≤ 11	-
D ₀	feed-hole diameter	4.0	± 0.2
t	total tape thickness with cardboard tape 0.5 ± 0.1 mm	0.65	± 0.2
	inspection level: S3 mechanical	-	1 %

Notes

1. Taped products with H = 45 ± 1, are available on request
2. D ≤ 5 max for 6404.338 to 221

Thermistors on tape

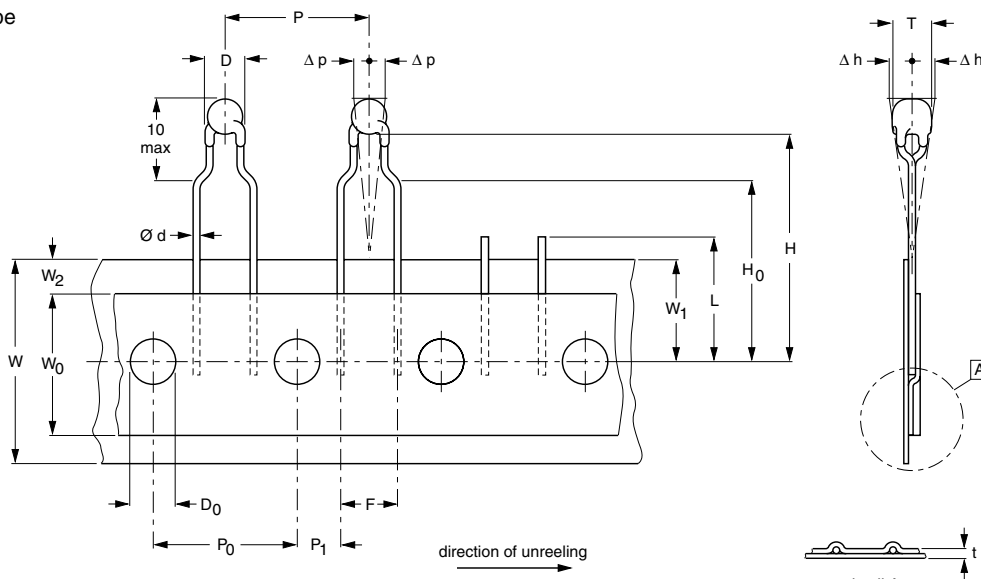

2E pitch
2322 640 3...

DIMENSIONS OF TAPE IN ACCORDANCE WITH "IEC 60286-2"			
SYMBOL	PARAMETER	DIMENSIONS (mm)	
		VALUE	TOLERANCE
D	body diameter ¹⁾	3.3	± 0.5
T	maximum total thickness ²⁾	≤ 3.2	-
d	lead diameter	0.6	± 0.06
P	pitch between thermistors	12.7	± 1
P ₀	feed-hole pitch (cumulative pitch error ± 0.2 mm/20 products)	12.7	± 0.3
P ₁	feed-hole centre to lead centre	3.85	± 0.7
Δp	component alignment	0	± 1.3
F	lead-to-lead distance	5.08	± 0.3
Δh	component alignment	0	± 2
W	tape width	18.0	+ 1/- 0.5
W ₀	hold-down tape width	≥ 12.5	-
W ₁	feed-hole position	9.0	+ 0.75/- 0.5
W ₂	hold-down tape position	≤ 3	-
H	component to tape centre	20	+ 2
H ₀	lead wire clinch height	16	± 0.5
L	length of snapped lead	≤ 11	-
D ₀	feed-hole diameter	4.0	± 0.3
t	total tape thickness with cardboard tape 0.5 ± 0.1 mm	0.7	± 0.2
	inspection level: S3 mechanical	-	1 %

Notes

1. D ≤ 5 max for 640 3. 338 to 640 4. 221
2. T ≤ 4 max for 640 3. 338 to 640 4. 221

REEL SPECIFICATIONS

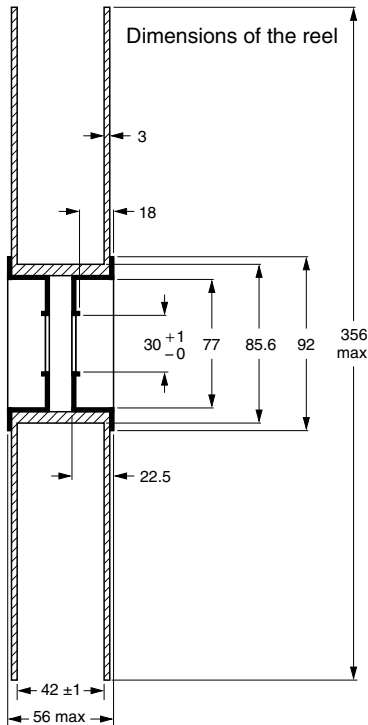

CODE NUMBERS AND RELEVANT PACKAGING QUANTITIES

PARAMETER	BULK	TAPE AND REEL ¹⁾ 1E pitch	TAPE AND REEL ¹⁾ 2E pitch
		2381 640 6.../ NTCLE100E3...B0	2381 640 4.../ NTCLE100E3...T1
Quantity	500	1500 per reel, 2 reels per box	1500 per reel, 2 reels per box

Note

- The maximum number of empty places per reel shall not exceed 0.1 % of the total number of components per reel. With no consecutive positions empty.

CHARACTERISTICS OF TAPED PRODUCTS

Minimum pull-out force of the component: 5 N

Minimum peel-off force of adhesive tape: 6N

Minimum tearing force tape: 15 N

Minimum pull-off force of tape-reel: 5 N

STORAGE CONDITIONS

Storage temperature range: - 25 to + 40 °C

Maximum relative humidity: 80 %

TESTS AND REQUIREMENTS

Essentially all tests are carried out in accordance with "IEC publication 60068-2; Environmental testing", except where indicated.

STABILITY TESTS				
CECC 32 100 CLAUSE	IEC 60068-2 TEST METHOD	TEST	PROCEDURE	REQUIREMENTS
D3; 4.20.1		endurance	25 °C; 1000 hours	$\Delta R/R < 1 \%$
	1	endurance	- 40 °C; 1000 hours	$\Delta R/R < 1 \%$
	539	endurance	500 mW; 55 °C; 1000 hours	$\Delta R/R < 3 \%$ ¹⁾
	2	dry heat, (steady state)	125 °C; 1000 hours	$\Delta R/R < 3 \%$
D1; 4.19	3	damp heat (steady state)	56 days at 40 °C; 90 to 95 % RH	$\Delta R/R < 3 \%$
C2; 4.14	14	rapid change of temperature	- 40 °C to + 125 °C; 50 cycles	$\Delta R/R < 2 \%$
Other applicable tests				
	21	robustness of leads: tensile strength bending	loading force 10 N loading force 5 N	$\Delta R/R \leq 1 \%$
	58	soldering: resistance to heat	240 °C max.; duration 4 s max. 265 °C max.; duration 5 s max.	$\Delta R/R \leq 1 \%$ ²⁾
	27	impact	free fall; 1 m	$\Delta R/R \leq 1 \%$
	29	shock	490 m/s; half sinewave	$\Delta R/R \leq 1 \%$
	45	resistance to solvent (isopropanol)	ambient temp for 5 min; 5 N with hydrophilic cotton wool	no traces of lacquer on cotton wool
	6	vibration	1.5 mm peak to peak: 10 to 58 Hz 10 gp: 50 to 500 Hz 1 octave/min. 2 hours in each direction in three orthogonal directions	no visible damage $\Delta R/R < 1 \%$
	2	inflammability	1980, needle flame test	non-flammable

Notes

- For $R_{25} \geq 100 \text{ k}\Omega$ the drift requirement is $\Delta R/R < 5 \%$
- For R_{25} from 2.2 k Ω to 10 k Ω , requirement is $\pm 2 \%$ max



Notice

Specifications of the products displayed herein are subject to change without notice. Vishay Intertechnology, Inc., or anyone on its behalf, assumes no responsibility or liability for any errors or inaccuracies.

Information contained herein is intended to provide a product description only. No license, express or implied, by estoppel or otherwise, to any intellectual property rights is granted by this document. Except as provided in Vishay's terms and conditions of sale for such products, Vishay assumes no liability whatsoever, and disclaims any express or implied warranty, relating to sale and/or use of Vishay products including liability or warranties relating to fitness for a particular purpose, merchantability, or infringement of any patent, copyright, or other intellectual property right.

The products shown herein are not designed for use in medical, life-saving, or life-sustaining applications. Customers using or selling these products for use in such applications do so at their own risk and agree to fully indemnify Vishay for any damages resulting from such improper use or sale.